

P&C

**design
mood**

Pacini  Cappellini

Pacini  Cappellini

index

indice prodotti

tables

axis pag .10 .15
hope pag .16 .25
cut pag .26 .29
mobius pag .30 .35
zeus pag .36 .47
young pag .48 .51
ten for ten pag .52 .55
dominique pag .56 .63
fashion pag .64 .67
plurimo pag .68 .71
elegance pag .72 .75
novecento pag .76 .79
cover pag .80 .83

cupboards

flair pag .158 .161
wing pag .162 .167
line pag .168 .171
weekly pag .172 .175
tiffany pag .176 .177

desks

athos pag .180 .181
abaco pag .182 .183

chairs & armchairs

gaya pag .86 .87
thelma pag .88 .89
kelly pag .90 .91
party pag .92 .93
eva pag .94 .97
freeline pag .98 .101
brenda pag .102 .103
ambra pag .104 .105
betty pag .106 .107
dafne pag .108 .109
cocoon pag .110 .115
relax pag .116 .117
kandy pag .118 .119

bookcases

elisabeth pag .122 .131
tres pag .132 .135
maze pag .136 .137
berchet pag .138 .139
trolley pag .140 .141

tv stands

sesamo pag .144 .147
lounge pag .148 .151
vision tv pag .152 .153
fabulus pag .154 .155

coffee tables

city pag .186 .187
denny pag .188 .189
corallo pag .190 .193
millerighe pag .194 .195
barnaby pag .196 .197
gong pag .198 .199
dominique pag .200 .203

accessories

dominique pag .206 .207
binario pag .208 .209
bunch pag .210 .211
cloud pag .212 .213
kali pag .214 .215
charme pag .216 .217
oblò pag .218 .219



profilo aziendale

La storia di Pacini & Cappellini nasce da tanti amori: il legno, la casa, l'abitare inteso come aspetto della quotidianità essenziale per il benessere delle persone. Partendo da queste basi, da più di trent'anni, l'azienda produce e distribuisce in tutto il mondo mobili e complementi d'arredo per la casa e la collettività: tavoli, sedie e poltrone, librerie e consolle, ma anche madie, porta-tv, realizzati interamente in Italia.

L'avventura di Alberto Pacini e Camillo Cappellini inizia quando capiscono che c'è soltanto un modo per dare concretezza alle loro passioni: realizzare mobili. Non oggetti qualsiasi, ma elementi speciali in grado di arricchire e ren-

dere unica la vita di ogni individuo. Forti di questa convinzione, i due soci scelgono di trasformarla in una vera missione, dando vita nel 1982 ad un progetto imprenditoriale basato sulla lavorazione artigianale di uno dei materiali più antichi, pregiati e funzionali: il legno. Così a Cabiato, in provincia di Como, nasce Pacini & Cappellini, che si afferma immediatamente come una delle realtà più solide del panorama italiano dell'arredamento.

La voglia di guardare al futuro, insieme alla volontà di assicurare continuità all'azienda, si realizza negli anni Novanta con l'ingresso dei figli, Luigi, Roberto, Moreno e Giorgio. L'idea alla base della nuova guida è mante-

nere ben saldi i valori tradizionali - facendo proprie la creatività, la passione e lo spirito di ricerca dei padri - e introducendo sostanziali novità. Da una produzione prettamente classica, improntata su lavorazioni complesse di ebanisteria e intaglio, la nuova squadra si avvia verso un nuovo progetto industriale, che permetterà un decisivo cambio di scala e il passaggio al design. Per riuscire nell'impresa, Pacini & Cappellini si avvale di tecnologie e processi industriali nuovi, e del contributo prezioso di un team di designer che darà vita a prodotti diventati icone, come i porta tv disegnati da Fabio Rebosio per la collezione Screen, o il tavolo Plurimo realizzato da Hanno Giesler.

company profile

The history of Pacini & Cappellini has born in between many loves: the wood, the home, the living thought as essential everyday life for the wellness of the people. Starting from those concepts, in the past 30 years, the Company manufactures and sells worldwide, furniture and accessories for residential environment and communities: dining tables, chairs and armchairs, bookcases and console but also cupboards and wall systems with TV stands, entirely manufactured in Italy.

The adventure of Alberto Pacini and Camillo Cappellini starts when they understood that, there is just one way to make their passions coming real: manufacturing

furniture. Not common objects but special elements able to enrich and make unique the life of everyone. Being sure of that, the two partners decided to play this mission establish in 1982 a real business project based on the artisan workmanship of one of the most antique, precious and functional we have in nature: the wood. So that in Cabiato, in the Como area, has been established Pacini & Cappellini, which became straight away one of the most solid business reality of the Italian furniture field.

The will of looking to the future, together with the will of secure the future of the Company, became real in the nineties when the son of the founder

Luigi, Roberto, Moreno and Giorgio, entered in the business. The idea is to keep firm the traditional values, learning from the fathers the creativity and passions and spirit of research, introducing substantial news. From a classical collection, based on complex inlay typical of the ebanisteria art, the new team is developing a business plan, oriented to the contemporary design. To be successful in this intent Pacini & Cappellini is using technologies and new industrial process, as well as the cooperation with a team of designer, developing products becoming icons like TV stands designed by Fabio Rebosio for the Screen Collection and the Plurimo Table designed by Hanno Giesler.



P&C collezione design mood

La necessità crescente di dare alle proprie collezioni una visione eclettica e un'interpretazione ancora più innovativa e contemporanea, ha spinto l'azienda a creare una nuova collezione, nata grazie a costanti rapporti con designer sempre nuovi, che oggi definiscono e raccontano al mondo la sua nuova identità, Mood Design. Questo assortito team di creativi – a cui si aggiunge la preziosa collaborazione di Matteo Nunziati e Stefano Bigi consente all'azienda di scrivere con successo la propria storia e affermare

i tratti tipici del suo stile: essenzialità, eleganza, contemporaneità. La spinta al rinnovamento non ha impedito a Pacini & Cappellini di mantenere intatta l'anima della propria produzione, il legno massello – la cui lavorazione avviene interamente all'interno – che ama lavorare con la cura dell'artigiano e lo stile del sarto, orientandosi sempre verso l'estrema attenzione ai dettagli, unita alle più innovative tecniche industriali e alla sostenibilità ambientale della

produzione. Sapien-temente accostato a materiali come il cristallo, il metallo, la pelle e i tessuti, il legno è ancora oggi il cuore pulsante dei mobili firmati Pacini & Cappellini, inconfondibili per il tono unico, prezioso e sofisticato, nonché emblemi di funzionalità, versatilità e puro design tutto italiano.

P&C design mood collection

The growing need of giving to the collections an eclectic vision and interpretation, even more innovative and contemporary, guided the Company to develop new collection, born from the solid and constant relationship with new designers, which are today defining and expressing the identity of the Company to the world, Mood Design. This team of creative people, has been enriched thanks to the cooperation of Matteo Nunziati and Stefano

Bigi enable the Company to write with success his history and assert the typical characteristics of its style: essentiality, elegance, and contemporaneity. The thrust of the renew has not arrested Pacini & Cappellini to remain unchanged the soul of its own collection, the solid wood – which is worked entirely inside the factory – with the care of the artisan and the style of a tailor, oriented to the extremely

attention to the details, in addition to the innovative industrial technologies and environment impact of the manufacturing processes. Skillfully kept near to other material like glass, metal, leather and fabrics, the wood is still today the beating heart of the furniture signed by Pacini & Cappellini, unique for their tone, precious and sophisticated, symbols of functionality, versatile and pure design made in Italy.

TABLES

tavoli

axis
hope
cut
mobius
zeus
young
ten for ten
dominique
fashion
plurimo
elegance
novecento
cover



design Stefano Bigi 2015

axis

Tavolo da pranzo con base in massello di noce canaletto o frassino. Basamento in metallo cromato. Piano in vetro temperato. Finiture disponibili: WG wengé, NC noce, TB tabacco, NK noce canaletto, Laccato opaco poro aperto.

Dining table with base in solid canaletto walnut or ash. Bottom plate in chrome-plated metal. Top in tempered glass. Available finishings: WG wengé, NC walnut, TB tabacco, NK canaletto walnut, Open pore matt lacquered.

table
cod.5494

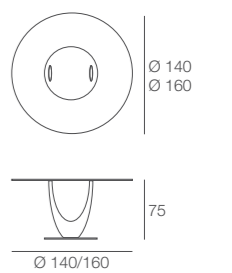



design Stefano Bigi 2015

axis

Tavolo da pranzo con basi in massello di noce canaletto o frassino. Basamenti in metallo cromato. Piano in vetro temperato. Finiture disponibili: WG wengé, NC noce, TB tabacco, NK noce canaletto, Laccato opaco poro aperto.

Dining table with bases in solid canaletto walnut or ash. Bottom plates in chrome-plated metal. Top in tempered glass. Available finishings: WG wengé, NC walnut, TB tobacco, NK canaletto walnut, Open pore matt lacquered.

table
cod.5494

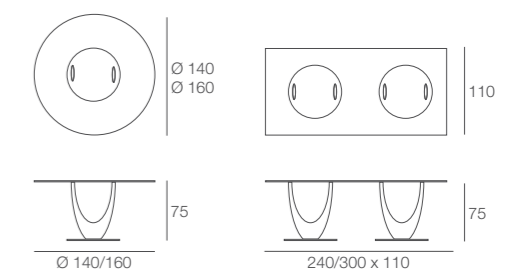





design Cesare Arosio 2015

hope

Tavolo da pranzo con struttura in massello di noce canaletto o frassino. Piano in legno placcato o in vetro temperato. Finiture disponibili: WG wengé, NC noce, TB tabacco, NK noce canaletto, Laccato opaco poro aperto.

Dining table with structure in solid canaletto walnut or ash. Wooden top veneered in canaletto walnut or ash or in tempered glass. Available finishings: WG wengé, NC walnut, TB tabacco, NK canaletto walnut, Open pore matt lacquered.

table
cod.5490

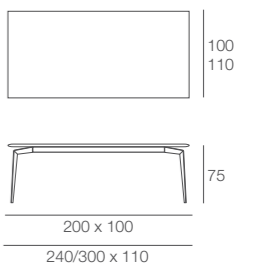





design Cesare Arosio 2015

hope

Tavolo da pranzo con struttura in massello di noce canaletto o frassino. Piano in legno placcato o in vetro temperato. Finiture disponibili: WG wengé, NC noce, TB tabacco, NK noce canaletto, Laccato opaco poro aperto.

Dining table with structure in solid canaletto walnut or ash. Wooden top veneered in canaletto walnut or ash or in tempered glass. Available finishings: WG wengé, NC walnut, TB tobacco, NK canaletto walnut, Open pore matt lacquered.

table
cod.5490

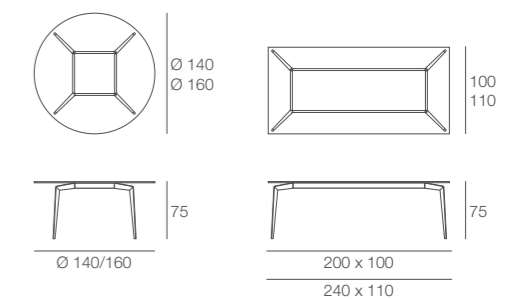







design Matteo Nunziati 2015

cut

table
cod.5491

Tavolo da pranzo con struttura in massello di noce canaletto o frassino. Piano in legno placcato noce canaletto, frassino o in marmo lucido. Finiture disponibili: WG wengé, NC noce, TB tabacco, NK noce canaletto, Laccato opaco poro aperto.

Dining table with structure in solid canaletto walnut or ash. Wooden top veneered in canaletto walnut, ash or in polished marble. Available finishes: WG wengé, NC walnut, TB tabacco, NK canaletto walnut, Open pore matt lacquered.

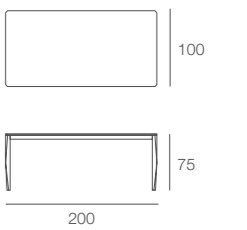





design Stefano Bigi 2015

mobius

Tavolo da pranzo con basi in massello di noce canaletto o frassino. Basamenti in metallo cromato. Piano in vetro temperato. Finiture disponibili: WG wengé, NC noce, TB tabacco, NK noce canaletto, Laccato opaco poro aperto.

Dining table with base in solid canaletto walnut or ash. Bottom plate in chrome-plated metal. Top in tempered glass. Available finishings: WG wengé, NC walnut, TB tobacco, NK canaletto walnut, Open pore matt lacquered.

table
cod.5493

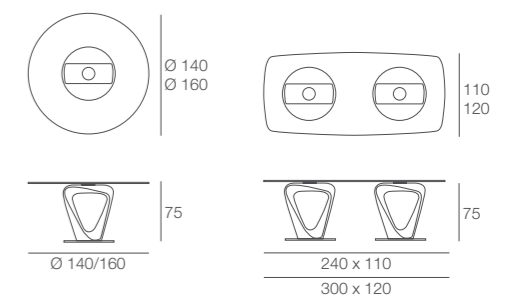

table size

design Stefano Bigi 2015

mobius

table
cod.5493







design Giuliano e Gabriele Cappelletti 2014

zeus

Tavolo da pranzo fisso o allungabile con basamento e struttura in massello di noce canaletto. Piano in legno, vetro, Cimento® o Laminam®. Nella versione allungabile meccanismo autocentrante in alluminio con prolunga interna placcata noce canaletto. Finiture disponibili: WG wengé, NK noce canaletto.

Dining table fix or extendible with base and structure in solid canaletto walnut. Top available in wood, glass, Cimento® or Laminam®. In the extendible version, self centering mechanism in aluminum and inner extension veneered canaletto walnut. Available finishings: WG wengé, NK canaletto walnut.

table
cod.5393

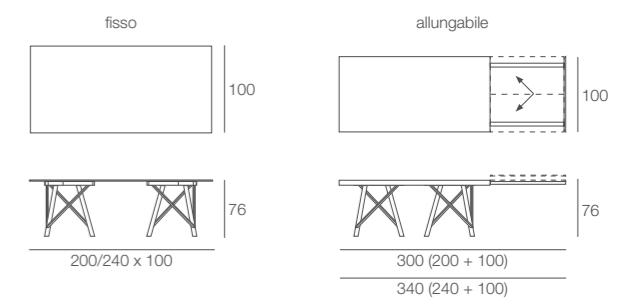







design Giuliano e Gabriele Cappelletti 2015

zeus

Tavolo da pranzo fisso
con basamento in mas-
sello di noce canaletto.
Piano in vetro temperato.
Finiture disponibili:
WG wengé, NK noce
canaletto.

Dining table fix with
base in solid canaletto
walnut. Top available in
tempered glass. Available
finishings: WG wengé,
NK canaletto walnut.

table
cod.5393

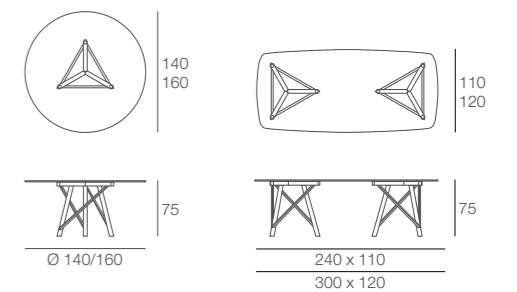







design Norberto Delfinetti e Monica Bernasconi 2008

young

Tavolo da pranzo con struttura in massello di noce canaletto e piano in vetro temperato naturale. Finiture disponibili: WG wengé, NK noce canaletto.

Dining table with structure in solid canaletto walnut and top in natural tempered glass. Available finishings: WG wengé, NK canaletto walnut.

table
cod.5410

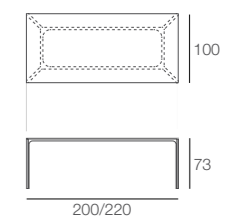

design Norberto Delfinetti e Monica Bernasconi 2008

young

table
cod.5410



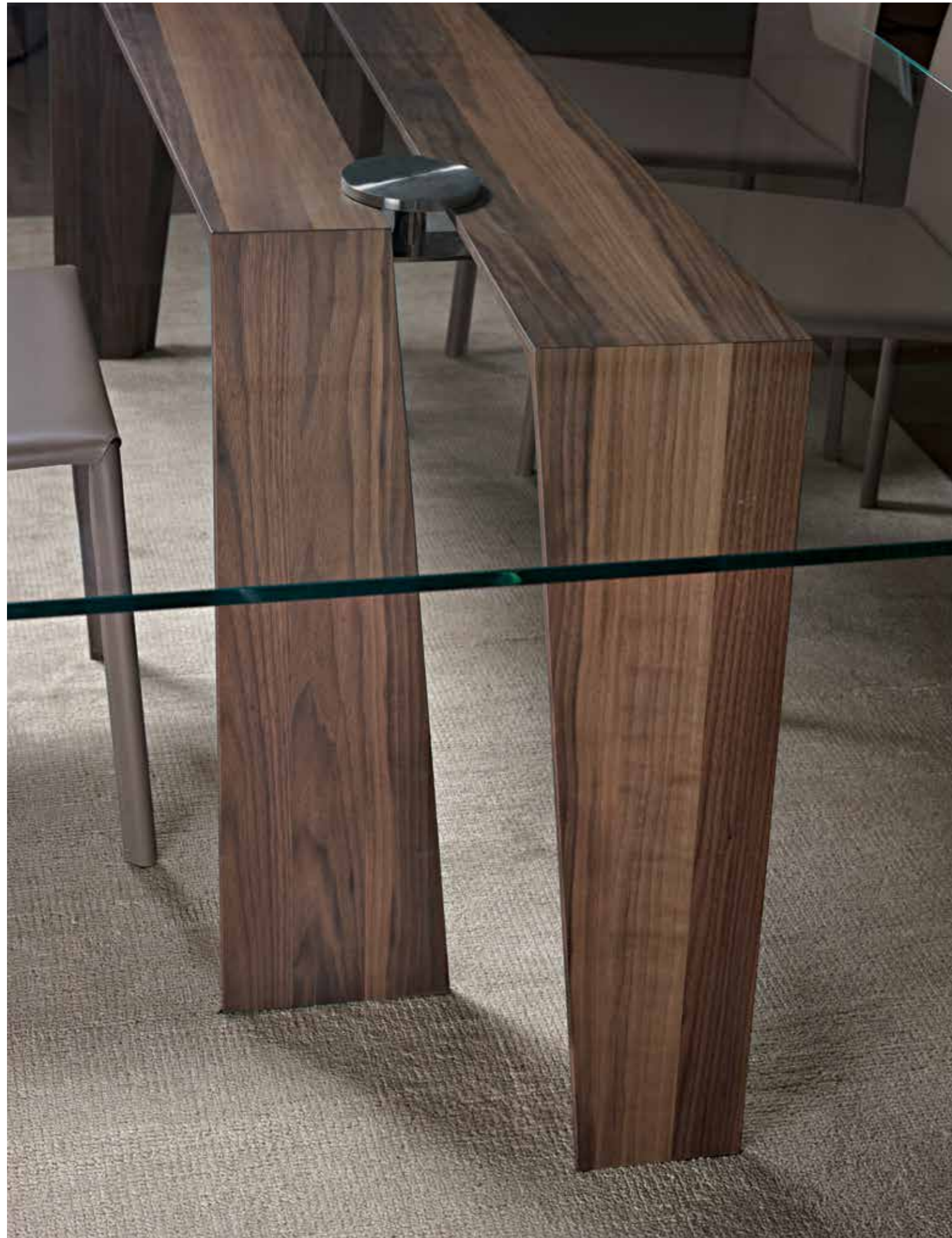

design Giuliano e Gabriele Cappelletti 2015

ten for ten

Tavolo da pranzo con basamenti in massello di noce canaletto o frassino. Piano in vetro naturale temperato. Finiture disponibili: WG wengé, NC noce, TB tabacco, NK noce canaletto, Laccato opaco poro aperto.

Dining table with supporting bases in solid canaletto walnut or ash. Top in natural tempered glass. Available finisings: WG wengé, NC walnut, TB tabacco, NK canaletto walnut, Open pore matt lacquered.

table
cod.5492

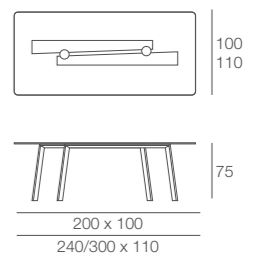





design Cesare Arosio e Beatrice Fanchini 2015

dominique

Tavolo da pranzo fisso con struttura in massello di frassino. Piano in legno placcato frassino, in Cimento® o in Laminam®. Finiture disponibili: FN frassino naturale, CL ciliegio americano, WG wengé, NC noce, TB tabacco, Laccato opaco poro aperto.

Fix dining table with structure in solid ash. Top veneered ash, in Cimento® or in Laminam®. Available finishings: FN natural ash, CL american cherry, WG wengé, NC walnut, TB tobacco, Open pore matt lacquered.

table
cod.5402

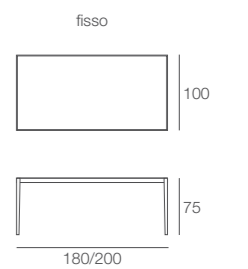





design Cesare Arosio e Beatrice Fanchini 2015

dominique

Tavolo da pranzo allungabile con struttura in massello di frassino. Piano in legno placcato frassino o in Cimento®. Meccanismo telescopico in alluminio con prolunghe interne placcate frassino. Finiture disponibili: FN frassino naturale, CL ciliegio americano, WG wengé, NC noce, TB tabacco, Laccato opaco poro aperto.

Extendible dining table with structure in solid ash. Top veneered ash or in Cimento®. Aluminium telescopic mechanism with inner extensions veneered ash. Available finishings: FN natural ash, CL american cherry, WG wengé, NC walnut, TB tobacco, Open pore matt lacquered.

table
cod.5402

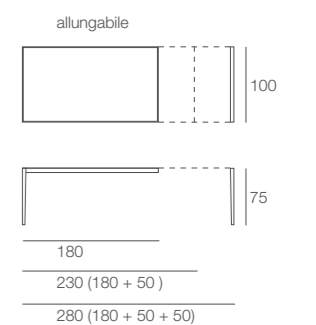





design Norberto Delfinetti e Monica Bernasconi 2008

fashion

Tavolo da pranzo con struttura in massello di frassino e piano placcato frassino. Finiture disponibili: WG wengé, NC noce, TB tabacco, Laccato opaco poro aperto.

Dining table with structure in solid ash and top veneered ash. Available finishings: WG wengé, NC walnut, TB tobacco, Open pore matt lacquered.

table
cod.5416

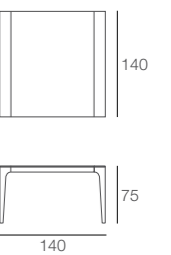

design Norberto Delfinetti e Monica Bernasconi 2008

fashion

table
cod.5416





design Hanno Giesler 2012

plurimo

table
cod.5483

Tavolo da pranzo quadrato maxi allungabile su due lati, in larghezza ed in profondità con prolunghe alloggiare all'interno. Struttura in massello di frassino. Piano in legno placcato frassino o in Cimento®. Prolunghe interne placcate. Meccanismo di apertura in alluminio. Modello brevettato e depositato. Finiture disponibili: CL ciliegio americano, WG wengé, NC noce, TB tabacco, Laccato opaco poro aperto, Decapato.

Maxi square table, extendible both in width and length, with extensions hidden inside. Structure in solid ash. Ash veneered top or Cimento®. Inner extensions veneered. Aluminium opening mechanism. Patented and registered model. Available finishings: CL american cherry, WG wengé, NC walnut, TB tobacco, Open pore matt lacquered, Decapé.

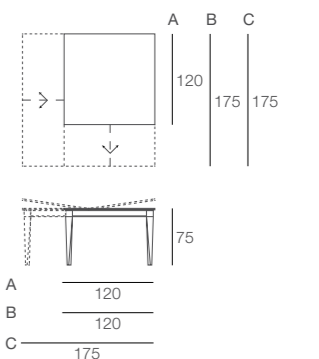
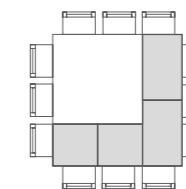
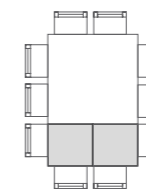
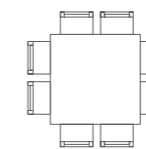

design Hanno Giesler 2012

plurimo

table
cod.5483





arch. Fabio Rebosio 2013

elegance

Tavolo da pranzo rotondo
allungabile con gambe
in massello di frassino.
Piano e prolunghe
placcate frassino. Mec-
canismo di apertura
in alluminio. Finiture
disponibili: WG wengé,
NC noce, TB tabacco,
Laccato opaco poro
aperto.

Round extendible dining
table with legs in solid
ash. Ash veneered top
and extensions.
Aluminium opening
mechanism. Available
finishings: WG wengé,
NC walnut, TB tobacco,
Open pore matt
lacquered.

table
cod.5399

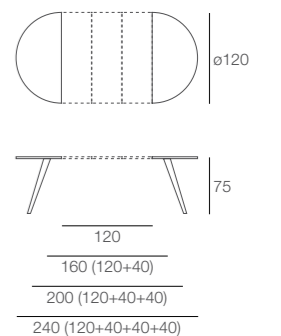





arch. Fabio Rebosio 2013

novecento

Tavolo da pranzo con gambe in massello di frassino. Piano in legno placcato frassino o in vetro naturale temperato. Finiture disponibili: FN frassino naturale, CL ciliegio americano, WG wengé, NC noce, TB tabacco, Laccato opaco poro aperto, Decapato.

Dining table with structure in solid ash. Top veneered ash or in natural tempered glass. Available finishings: FN natural ash, CL american cherry, WG wengé, NC walnut, TB tobacco, Open pore matt lacquered, Decapé.

table
cod.5408

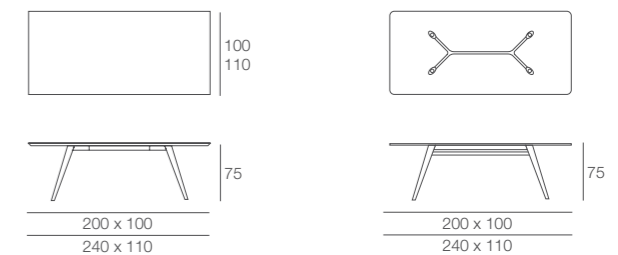





design Giuliano Cappelletti 2011

cover

Tavolo da pranzo con struttura in massello di frassino e piano placcato frassino. Particolari in alluminio brillantato. Finiture disponibili: FN frassino naturale, WG wengé, NC noce, TB tabacco, Laccato opaco poro aperto.

Dining table with structure in solid ash and top veneered ash. Details in polished aluminium. Available finishings: FN natural ash, WG wengé, NC walnut, TB tobacco, Open pore matt lacquered.

table
cod.5404.2

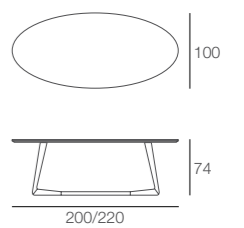



CHAIRS & ARMCHAIRS

sedie e
poltroncine

gaya
thelma
kelly
party
eva
freeline
brenda
ambra
betty
dafne
cocoon
relax
kandy



design Stefano Bigi 2015

gaya

Sedia e poltroncina con struttura in massello di noce canaletto o frassino. Seduta rivestita in pelle, ecopelle o tessuto della collezione. Finiture disponibili: WG wengé, NC noce, TB tabacco, NK noce canaletto, Laccato opaco poro aperto.

Chair and small armchair with structure in solid canaletto walnut or ash. Seat covered in leather, eco-leather or fabrics of the collection. Available finishings: WG wengé, NC walnut, TB tobacco, NK canaletto walnut, Open pore matt lacquered.

chair
cod.5464
armchair
cod.5464.1

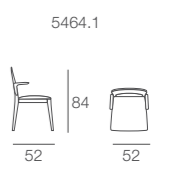
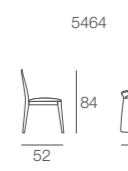



arch. Fabio Rebosio 2015

thelma

Sedia e poltroncina con struttura in massello di noce canaletto. Seduta rivestita in pelle, ecopelle o tessuto della collezione. Finiture disponibili: WG wengé, NK noce canaletto.

Chair and small armchair with structure in solid canaletto walnut. Seat covered in leather, eco-leather or fabric of the collection. Available finishings: WG wengé, NK canaletto walnut.

chair
cod.5466
armchair
cod.5466.1

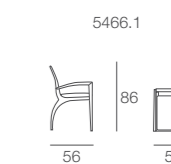
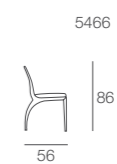



design Matteo Nunziati 2015

kelly

Sedia con struttura in massello di noce canaletto o frassino. Seduta e schienale rivestiti in pelle, ecopelle o tessuto della collezione. Finiture disponibili: WG wengé, NC noce, TB tabacco, NK noce canaletto, Laccato opaco poro aperto.

Chair with structure in solid canaletto walnut or ash. Seat and backrest covered in leather, eco-leather or fabric of the collection. Available finishings: WG wengé, NC walnut, TB tobacco, NK canaletto walnut, Open pore matt lacquered.

chair
cod.5465

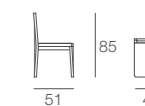



design Giuliano e Gabriele Cappelletti 2014

party

Sedia con struttura
in massello di noce
canaletto. Seduta e
schienale rivestito in
pelle, ecopelle o tessuto
della collezione. Finiture
disponibili: WG wengé,
NK noce canaletto.

Chair with structure in
solid canaletto walnut.
Seat and backrest
covered in leather, eco-
leather or fabric of the
collection. Available
finishings: WG wengé,
NK canaletto walnut.

chair
cod.5467

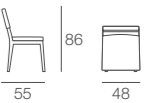



Studio Tecnico Pacini&Cappellini 2014

eva

Sedia con struttura in massello di frassino. Seduta e schienale rivestiti in pelle, ecopelle o tessuto della collezione. Finiture disponibili: FN frassino naturale, CL ciliegio americano, WG wengé, NC noce, TB tabacco, Laccato opaco poro aperto.

Chair with structure in solid ash. Seat and backrest covered in leather, eco-leather or fabric of our collection. Available finishings: FN natural ash, CL american cherry, WG wengé, NC walnut, TB tobacco, Open pore matt lacquered.

chair
cod.5468

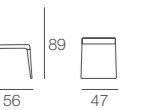



Studio Tecnico Pacini&Cappellini 2014

eva

Sedia con struttura in
massello di frassino.
Interamente rivestita in
pelle, ecopelle o tessuto
della collezione.

Chair with structure
in solid ash covered in
leather, eco-leather or
fabric of the collection.

chair
cod.5468.T

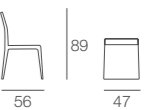



design Norberto Delfinetti e Monica Bernasconi 2008

freeline

Sedia con struttura in metallo. Interamente rivestita in pelle, ecopelle o tessuto della collezione.

Chair with metal structure covered in leather, eco-leather or fabric of the collection.

chair
cod.5428

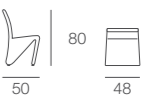

design Norberto Delfinetti e Monica Bernasconi 2008

freeline

chair
cod.5428





Studio Tecnico Pacini&Cappellini 2014

brenda

Sedia con struttura in massello di frassino. Seduta e schienale rivestiti in pelle, ecopelle o tessuto della collezione. Finiture disponibili: FN frassino naturale, CL ciliegio americano, WG wengé, NC noce, TB tabacco, Laccato opaco poro aperto.

Chair with structure in solid ash. Seat and backrest covered in leather, eco-leather or fabric of the collection. Available finishings: FN natural ash, CL american cherry, WG wengé, NC walnut, TB tobacco, Open pore matt lacquered.

chair
cod.5469

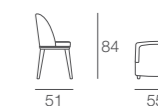



Studio Tecnico Pacini&Cappellini 2013

ambra

Sedia con struttura in massello di frassino, scocca curvata rivestita in pelle, ecopelle o tessuto della collezione. Finiture disponibili: FN frassino naturale, CL ciliegio americano, WG wengé, NC noce, TB tabacco, Laccato opaco poro aperto, Decapato.

Chair with structure in solid ash, curved shell covered in leather, eco-leather or fabric of the collection. Available finishings: FN natural ash, CL american cherry, WG wengé, NC walnut, TB tobacco, Open pore matt lacquered, Decapé.

chair
cod.5441

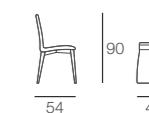



Studio Tecnico Pacini&Cappellini 2011

betty

Sedia e poltroncina con struttura in massello di frassino, seduta rivestita in pelle, ecopelle o tessuto della collezione. Finiture disponibili: FN frassino naturale, CL ciliegio, americano WG wengé, NC noce, TB tabacco, Laccato opaco poro aperto, Decapato.

Chair and small armchair with structure in solid ash, seat covered in leather, eco-leather or fabric of our collection. Available finishings: FN natural ash, CL american cherry, WG wengé, NC walnut, TB tobacco, Open pore matt lacquered, Decapè.

chair
cod.5448
armchair
cod.5448.1

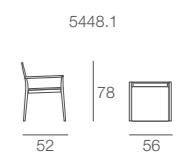
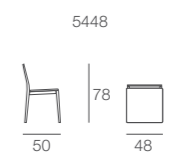



Studio Tecnico Pacini&Cappellini 2015

dafne

Sedia con struttura in metallo, rivestita in cuoio rigenerato nei colori della collezione.

Chair with structure in metal, covered in regenerated leather in the colours of the collection.

chair
cod.5445.1

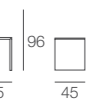



design Giuliano e Gabriele Cappelletti 2014

COCOON

Divanetto con struttura in massello di noce canaletto o frassino, rivestito in pelle, ecopelle o tessuto della collezione. Finiture disponibili: FN frassino naturale, CL ciliegio americano, WG wengé, NC noce, TB tabacco, NK noce canaletto, Laccato opaco poro aperto.

Small sofa with solid canaletto walnut or ash structure, covered in leather, eco-leather or fabric of the collection. Available finishings: FN natural ash, CL american cherry, WG wengé, NC walnut, TB tobacco, NK canaletto walnut, Open pore matt lacquered.

sofa
cod.5461

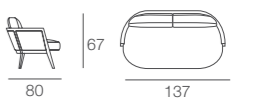



design Giuliano e Gabriele Cappelletti 2014

COCOON

Poltrona con struttura
in massello di noce
canaletto o frassino,
rivestita in pelle, ecopelle
o tessuto della collezione.
Finiture disponibili:
FN frassino naturale,
CL ciliegio americano,
WG wengé, NC noce,
TB tabacco, NK noce
canaletto, Laccato opaco
poro aperto.

Armchair in solid
canaletto walnut or ash,
covered in leather, eco-
leather or fabric of the
collection. Available fi-
nishings: FN natural ash,
CL american cherry, WG
wengé, NC walnut, TB
tobacco, NK canaletto
walnut, Open pore matt
lacquered.

armchair
cod.5460

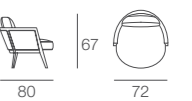



5 5 5 5 5
5 5 5 5 5
5 5 5 5 5



design Studio Controdesign 2011

relax

Poltroncina in massello di frassino, rivestita in pelle o ecopelle della collezione. Finiture disponibili: WG wengé, NC noce, TB tabacco, Laccato opaco poro aperto.

Armchair in solid ash, covered in leather or eco-leather of the collection. Available finishings: WG wengé, NC walnut, TB tobacco, Open pore matt lacquered.

armchair
cod.5439

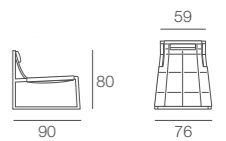



Studio Tecnico Pacini&Cappellini 2011

kandy

Poltroncina in massello di frassino rivestita in pelle, ecopelle o tessuto della collezione. Finiture disponibili: FN frassino naturale, CL ciliegio americano, WG wengé, NC noce, TB tabacco, Laccato opaco poro aperto.

Small armchair with solid ash structure, covered in leather, eco-leather or fabric of the collection. Available finishings: FN natural ash, CL american cherry, WG wengé, NC walnut, TB tobacco, Open pore matt lacquered.

armchair
cod.5440

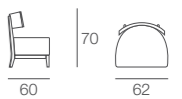

BOOKCASES

liberie

elisabeth
tres
maze
berchet
trolley



design Cesare Arosio e Beatrice Fanchini 2014

elisabeth

bookcase
cod.5549

Libreria modulare con struttura placcata in noce canaletto o in fibra di legno. Ripiani, divisori e pannelli posteriori portanti placcati noce canaletto o in fibra di legno. Possibilità di montaggio ad angolo. Finiture disponibili: WG wengé, NK noce canaletto, Laccato opaco poro chiuso.

Modular bookcase with veneered canaletto walnut or in fiberboard. Shelves, frame and supporting back panels in veneered canaletto walnut or in fiberboard. Possible assembling as corner. Available finishings: WG wengé, NK canaletto walnut, Open pore matt lacquered.

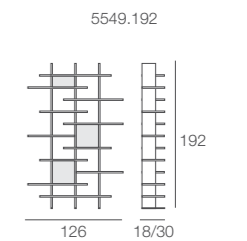







design Cesare Arosio e Beatrice Fanchini 2014

elisabeth

bookcase
cod.5549

Libreria modulare con struttura placcata in noce canaletto o in fibra di legno. Ripiani, divisori e pannelli posteriori portanti placcati noce canaletto o in fibra di legno. Disponibile nella versione a parete o divisororia con possibilità di montaggio ad angolo e/o fissaggio a soffitto. Non autoportante. Finiture disponibili: WG wengé, NK noce canaletto, Laccato opaco poro chiuso.

Modular bookcase with veneered canaletto walnut or in fiberboard. Shelves, frame and supporting back panels in veneered canaletto walnut or in fiberboard. Available to be hang to the wall or as partition, possible the assembling as corner and fixed to the ceiling. The system is not self-supporting. Available finishings: WG wengé, NK canaletto walnut, Closed pore matt lacquered.



5549.256

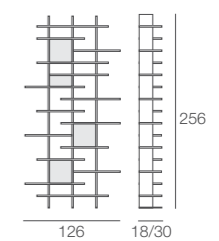



design Cesare Arosio e Beatrice Fanchini 2014

elisabeth

Libreria modulare con struttura placcata in noce canaletto o in fibra di legno. Ripiani, divisori e pannelli posteriori portanti placcati noce canaletto o in fibra di legno. Disponibile nella versione a parete o divisoria con possibilità di montaggio ad angolo e/o fissaggio a soffitto. Non autoportante. Finiture disponibili: WG wengé, NK noce canaletto, Laccato opaco poro chiuso.

Modular bookcase with veneered canaletto walnut or in fiberboard. Shelves, frame and supporting back panels in veneered canaletto walnut or in fiberboard. Available to be hang to the wall or as partition, possible the assembling as corner and fixed to the ceiling. The system is not self-supporting. Available finishings: WG wengé, NK canaletto walnut, Closed pore matt lacquered.

bookcase
cod.5549



5549.256

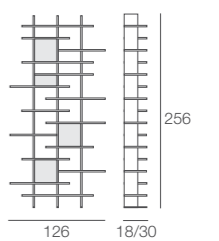



design Norberto Delfinetti e Monica Bernasconi 2008

tres

Libreria con struttura
in alluminio placcato
noce canaletto. Ripiani
placcati noce canaletto.
Finiture disponibili:
WG wengé, NK noce
canaletto.

Bookcase with alumi-
nium structure veneered
canaletto walnut. Shelves
veneered canaletto wal-
nut. Available finishings:
WG wengé, NK canaletto
walnut.

bookcase
cod.5551

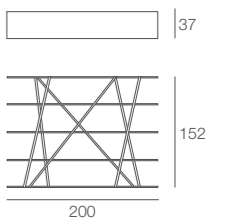

design Norberto Delfinetti e Monica Bernasconi 2008

tres

bookcase
cod.5551





design Norberto Delfinetti e Monica Bernasconi 2009

maze

Libreria componibile da parete con struttura placata noce canaletto o in fibra di legno. Possibilità di fissaggio in orizzontale o verticale. Finiture disponibili: WG wengé, NK noce canaletto, Laccato opaco poro chiuso.

Modular wall bookcase with structure veneered canaletto walnut or fiberboard. It is possible to hang it vertically or horizontally. Available finishings: WG wengé, NK canaletto walnut, Closed pore matt lacquered.

bookcase
cod.5543

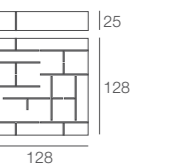



design Cristina Paelari 2015

berchet

Libreria da parete con struttura, ripiani e divisori placcati in noce canaletto o frassino. Antine scorrevoli in vetro verniciato. Finiture disponibili: WG wengé, NC noce, TB tabacco, NK noce canaletto, Laccato opaco poro aperto.

Wall bookcase with structure, shelves and frames veneered canaletto walnut or ash. Painted glass sliding doors. Available finishes: WG wengé, NC walnut, TB tobacco, NK canaletto walnut, Open pore matt lacquered.

bookcase
cod.5544

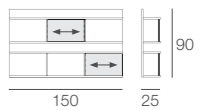



arch. Fabio Rebosio 2014

trolley

Elemento portlibri
girevole con struttura,
base e ripiani placcati
noce canaletto. Finiture
disponibili: WG wengé,
NK noce canaletto.

Revolving bookends
element with structure,
base and shelves ve-
neered canaletto walnut.
Available finishings: WG
wengé, NK canaletto
walnut.

bookends element
cod.5561
cod.5562

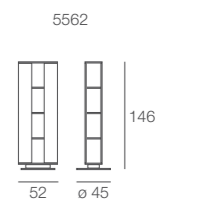
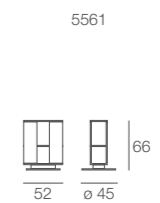

TV STANDS

porta tv

sesamo
lounge
vision tv
fabulus





A



A



B



C

arch. Fabio Rebosio 2014

sesamo

tv stand
cod.5335

Porta tv apribile con pannello frontale impiallacciato noce canaletto o frassino. Possibilità di varie attrezzature per l'interno, rifinito in materiale decorativo color avorio. Dotato di ruota, mensola porta decoder in alluminio ossidato e barra porta tv universale. Predisposto per l'alloggiamento ed il cablaggio cavi. Finiture disponibili: FN frassino naturale, WG wengé, NC noce, TB tabacco, NK noce canaletto, Laccato opaco poro aperto.

TV stand with openable front panel veneered canaletto walnut or ash. Inside accessories available in various configurations, finished with decorative material, ivory color. Equipped with wheel, oxidized aluminium shelf for decoder appliance and universal TV bar. Predisposed for wire cable raceway. Available finishings: FN natural ash, WG wengé, NC walnut, TB tobacco, NK canaletto walnut, Open pore matt lacquered.

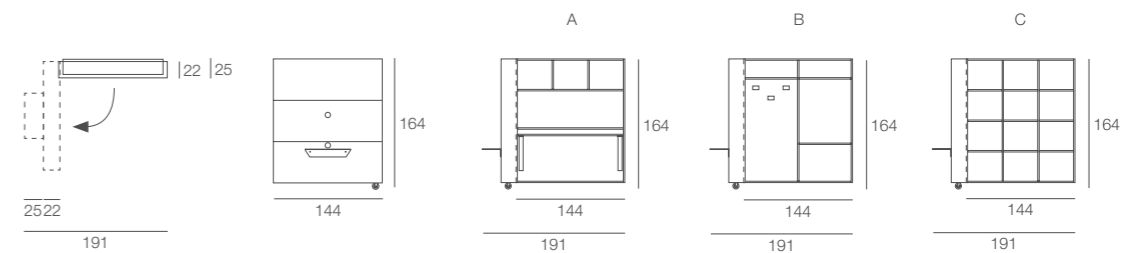



arch. Fabio Rebosio 2015

lounge

Elemento porta tv con base girevole (360°) placcata noce canaletto o frassino. Pannello porta tv placcato noce canaletto o frassino, predisposto per il cablaggio cavi. Dotato di mensola porta decoder in alluminio ossidato e barra porta tv universale. Finiture disponibili: FN frassino naturale, CL ciliegio americano, WG wengé, NC noce, TB tabacco, NK noce canaletto, Laccato opaco poro aperto.

TV stand element with revolving base (360°) veneered canaletto walnut or ash. TV stand panel veneered canaletto walnut or ash, predisposed for cables raceway. Equipped with oxidized aluminium shelf for decoder appliance and universal TV bar. Available finishings: FN natural ash, CL american cherry, WG wengé, NC walnut, TB tobacco, NK canaletto walnut, Open pore matt lacquered.

tv stand
cod.5340

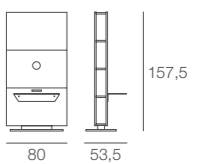



arch. Fabio Rebosio 2015

lounge

Elemento porta tv con base girevole (360°) placcata noce canaletto o frassino. Pannello porta tv placcato noce canaletto o frassino, predisposto per il cablaggio cavi. Dotato di mensola porta decoder in alluminio ossidato e barra porta tv universale. Finiture disponibili: FN frassino naturale, CL ciliegio americano, WG wengé, NC noce, TB tabacco, NK noce canaletto, Laccato opaco poro aperto.

TV stand element with revolving base (360°) veneered canaletto walnut or ash. TV stand panel veneered canaletto walnut or ash, predisposed for cables raceway. Equipped with oxidized aluminium shelf for decoder appliance and universal TV bar. Available finishings: FN natural ash, CL american cherry, WG wengé, NC walnut, TB tobacco, NK canaletto walnut, Open pore matt lacquered.

tv stand
cod.5340

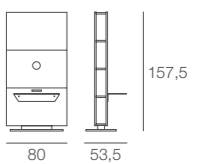



design Giuliano e Gabriele Cappelletti 2014

vision tv

Porta tv con struttura, pannello e ripiani placcati noce canaletto o frassino. Dotato di barra porta tv universale. Predisposto per alloggiamento ed il cablaggio cavi. Finiture disponibili: WG wengé, NC noce, TB tabacco, NK noce canaletto, Laccato opaco poro aperto.

TV stand with structure, panel and shelves veneered canaletto walnut or ash. Equipped with universal TV bar. Predisposed for cables raceway. Available finishings: WG wengé, NC walnut, TB tobacco, NK canaletto walnut, Open pore matt lacquered.

tv stand
cod.5333

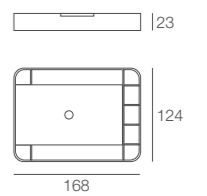



arch. Fabio Rebosio 2012

fabulus

tv stand
cod.5329

Elemento porta tv con base girevole o fissa rivestita in supermirror lucido. Struttura in massello di noce canaletto o frassino con ante placcate, apertura push & pull. Top in legno placcato o in vetro verniciato. Finiture disponibili: WG wengé, NC noce, TB tabacco, NK noce canaletto, Laccato opaco poro aperto.

TV stand element with revolving or fix base, covered with polished super mirror finish. Structure with solid canaletto walnut or ash and veneered doors, push&pull opening. Veneered or retro lacquered glass top. Available finishings: WG wengé, NC walnut, TB tobacco, NK canaletto walnut, Open pore matt lacquered.

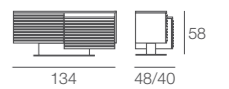

CUPBOARDS

madie

flair
wing
line
weekly
tiffany



design Giuliano Cappelletti 2013

flair

Madia con struttura plac-
cata frassino e profili in
massello. Ante placcate
frassino o con inserti
in Cimento®. Ripiani
interni in legno. Finiture
disponibili: WG wengé,
NC noce, TB tabacco,
Laccato opaco poro
aperto.

Cupboard with structure
veneered ash and
outline in solid ash.
Doors veneered ash or
in Cimento®. Wooden
shelves inside. Avail-
able finishings: WG
wengé, NC walnut, TB
tobacco, Open pore matt
lacquered.

cupboard
cod.5578

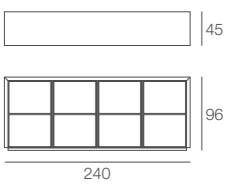

design Giuliano Cappelletti 2013

flair

cupboard
cod.5578





arch. Fabio Rebosio 2014 **система wing**

Madia con struttura
placcata noce canaletto.
Basamento in massello.
Top, ante, cassetti e
ripiani placcati. Finiture
disponibili: WG wengé,
NK noce canaletto.

Cupboard with structure
veneered canaletto wal-
nut. Base in solid wood.
Top, doors, drawers
and shelves veneered.
Available finishings: WG
wengé, NK canaletto
walnut.

cupboard
comp. 2

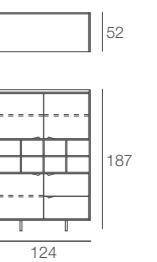



arch. Fabio Rebosio 2014 **sistema wing**

Madia con struttura plac-
cata noce canaletto.
Basamento in massello.
Ante, cassetti e ripiani
placcati. Piano superiore
placcato o in Laminam®.
Finiture disponibili:
WG wengé, NK noce
canaletto.

Cupboard with veneered
canaletto walnut.
Base in solid wood.
Doors, drawers and
inner shelves veneered.
Top veneered or in
Laminam®. Available
finishings: WG wengé,
NK canaletto walnut.

cupboard
comp. 6

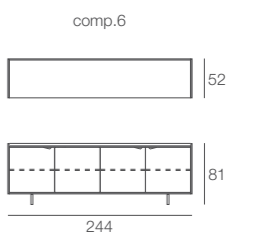
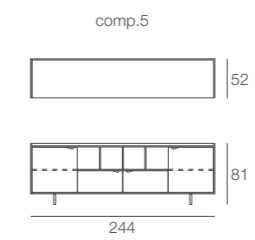





design Giuliano Cappelletti 2013

line

Madia con struttura placcata ed in massello di frassino. Piano superiore placcato. Ripiani interni in vetro naturale. Finiture disponibili: WG wengé, NC noce, TB tabacco, Laccato opaco poro aperto.

Cupboard with structure veneered and in solid ash. Veneered ash top. Inner shelves in natural glass. Available finishings: WG wengé, NC walnut, TB tobacco, Open pore matt lacquered.

cupboard
cod.5577

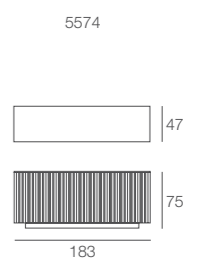
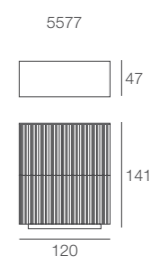

design Giuliano Cappelletti 2011

line

cupboard
cod.5574





design Giuliano e Gabriele Cappelletti 2013

weekly

Mobile contenitore con struttura placcata ed in massello di noce canaletto. Divisori placcati, ripiani placcati e rivestiti in pelle, cassetti e vani a giorno placcati con frontali in metallo brunito.
 Finiture disponibili: WG wengé, NK noce canaletto.

Cabinet with veneered structure and solid canaletto walnut. Inner partitions and shelves veneered and covered in leather, drawers and open units veneered with front in burnished metal.
 Available finishings: WG wengé, NK canaletto walnut.

cabinet
 cod.5579



B



A





design Elena Viganò 2009

tiffany

Settimanale con struttura
placcata frassino o in fi-
bra di legno. Cassetti, do-
tati di guide blue-motion,
con frontali in massello
di frassino o tulipier.
Finiture disponibili: WG
wengé, NC noce, TB
tabacco, Laccato opaco
poro aperto, Laccato
opaco poro chiuso, Lac-
cato brillante.

Seven drawer with
structure veneered in
ash or in fiberboard.
Drawers, equipped with
blue-motion guides,
with fronts in solid ash
or tulipwood. Avail-
able finishings: WG
wengé, NC walnut, TB
tobacco, Open pore matt
lacquered, Closed pore
matt lacquered, Glossy
lacquered.

seven drawer
cod.5572



DESKS

scrittoi

athos
abaco



arch. Fabio Rebosio 2011

athos

Scrittoio con struttura
in massello di frassino
dotato di cassetto estra-
bile ed inserto in cuoio.
pelle o ecopelle. Finiture
disponibili: FN frassino
naturale, CL ciliegio
americano, WG wengé,
NC noce, TB tabacco.
Laccato opaco poro
aperto.

Writing desk with
structure in solid ash,
equipped with pull-out
drawer and leather or
eco-leather insert. Avail-
able finishings: FN natural
ash, CL american cherry,
WG wengé, NC walnut,
TB tobacco, Open pore
matt lacquered.

desk
cod.5470

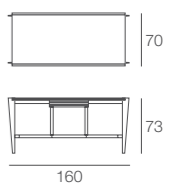



arch. Fabio Rebosio 2015

abaco

Scrivania con struttura in massello di noce canaletto o frassino. Top in vetro temperato e ripiano placcato noce canaletto o frassino. Finiture disponibili: WG wengé, NC noce, TB tabacco, NK noce canaletto, Laccato opaco poro aperto.

Writing desk with structure in solid canaletto walnut or ash. Transparent glass top and shelf veneered canaletto walnut or ash. Available finishings: WG wengé, NC walnut, TB tobacco, NK canaletto walnut, Open pore matt lacquered.

desk
cod.5472

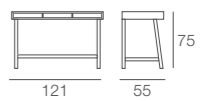

COFFEE TABLES

tavolini

city
denny
corallo
millerighe
barnaby
gong
dominique



arch. Fabio Rebosio 2011

city

Tavolino con struttura in massello di noce canaletto o frassino. Piano in legno placcato o in marmo lucido. Finiture disponibili: FN frassino naturale, WG wengé, NC noce, TB tabacco, NK noce canaletto, Laccato opaco poro aperto.

Coffee table with structure in solid canaletto walnut or ash. Top veneered canaletto walnut, ash or in polished marble. Available finishes: FN natural ash, WG wengé, NC walnut, TB tobacco, NK canaletto walnut, Open pore matt lacquered.

coffee table
cod.5391



5391.50

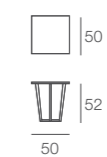

5391.80

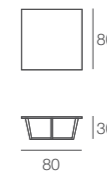

5391.120

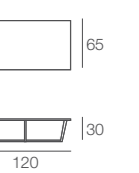



arch. Fabio Rebosio 2015

denny

Tavolino con struttura in massello e piano legno placcato noce canaletto. Finiture disponibili: WG wengé, NK noce canaletto.

Coffee table with solid wood structure and top veneered canaletto walnut. Available finishings: WG wengé, NK canaletto walnut.

coffee table
cod.5372



5372.45



5372.55



5372.90





arch. Fabio Rebosio 2015

corallo

Tavolino con piano superiore in vetro e piano inferiore placcato noce canaletto. Particolari in alluminio placcato noce canaletto. Finiture disponibili: WG wengé, NK noce canaletto.

Coffee table with upper surface in glass and lower surface veneered canaletto walnut. Aluminium details veneered canaletto walnut Available finishings: WG wengé, NK canaletto walnut.

coffee table
cod.5375

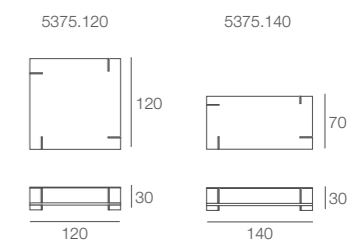

coffee table
cod.5375



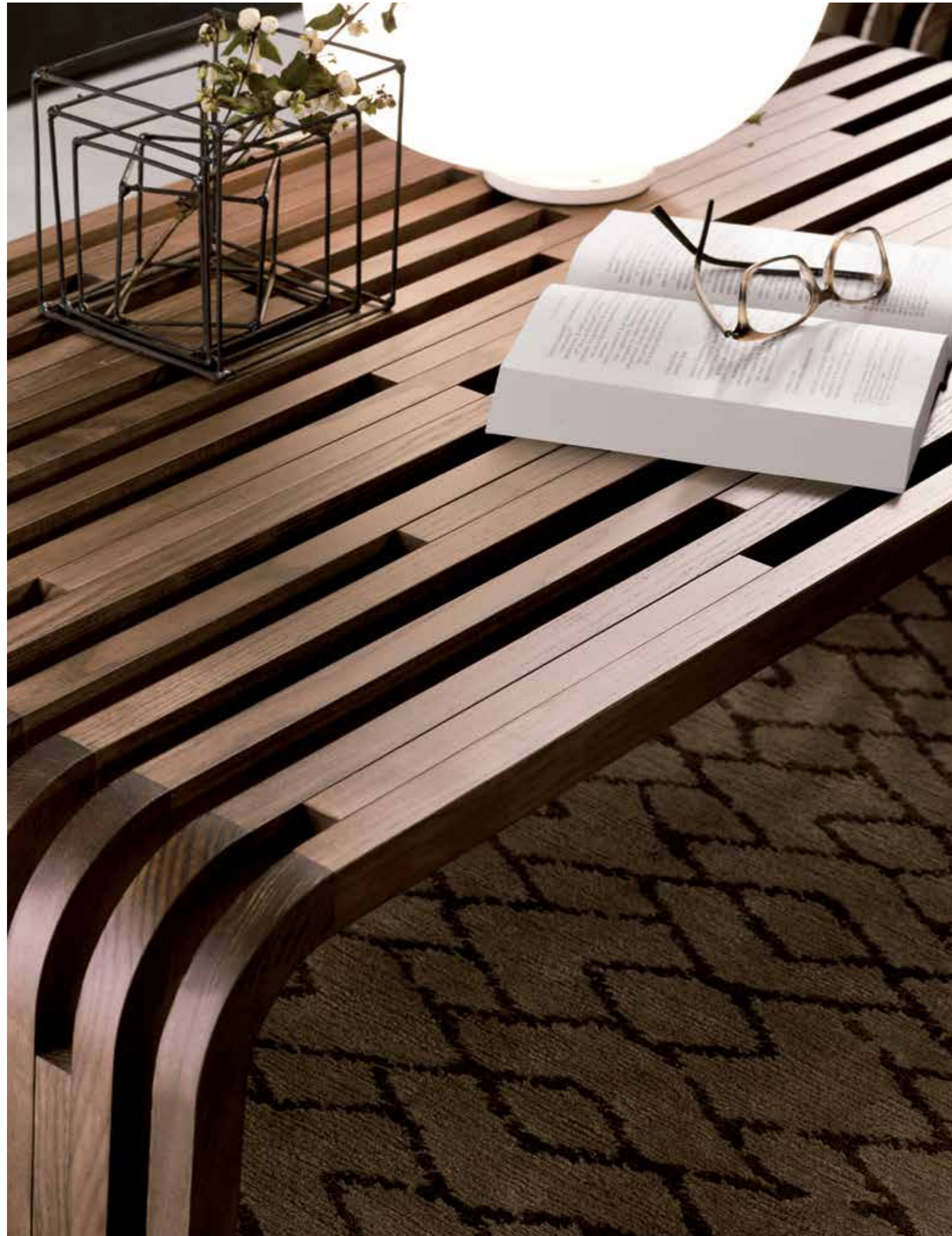

design Norberto Delfinetti e Monica Bernasconi 2009

millerighe

Tavolino con struttura in massello di noce canaletto o frassino. A richiesta: cuscino in appoggio rivestito nei tessuti della collezione. Finiture disponibili: FN frassino naturale, CL ciliegio americano, WG wengé, NC noce, TB tabacco, NK noce canaletto, Laccato opaco poro aperto.

Coffee table with structure in solid canaletto walnut or ash. Upon request: seat cushion covered in the fabrics of the collection. Available finishings: FN natural ash, CL american cherry, WG wengé, NC walnut, TB tobacco, NK canaletto walnut, Open pore matt lacquered.

coffee table
cod.5531

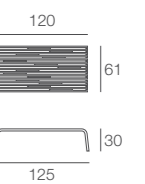



arch. Fabio Rebosio 2015

barnaby

Tavolino con struttura in massello di frassino. Top in legno placcato frassino o in vetro verniciato. Finiture disponibili: FN frassino naturale, CL ciliegio americano, WG wengé, NC noce, TB tabacco, Laccato opaco poro aperto.

Coffee table with solid ash structure. Veneered ash top or retro lacquered glass. Available finishes: FN natural ash, CL american cherry, WG wengé, NC walnut, TB tobacco, Open pore matt lacquered.

coffee table
cod.5381



5381.120

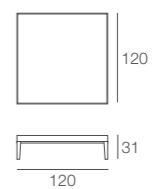

5381.125

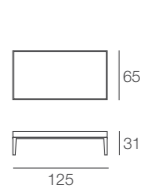



Studio Tecnico Pacini&Cappellini 2011

gong

Tavolino con struttura e piano/vassoio in massello di frassino. Finiture disponibili: FN frassino naturale, WG wengé, NC noce, TB tabacco, Laccato opaco poro aperto.

Coffee table with structure and top/tray in solid ash. Available finishings: FN natural ash, WG wengé, NC walnut, TB tobacco, Open pore matt lacquered.

coffee table
cod.5388

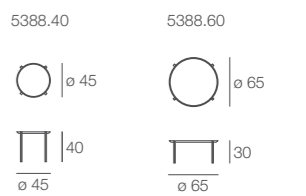



design Cesare Arosio e Beatrice Fanchini 2014

dominique

Tavolino rotondo con struttura in massello di frassino. Piano in legno placcato frassino, in Cimento® o in marmo lucido. Finiture disponibili: FN frassino naturale CL ciliegio americano WG wengé, NC noce, TB tabacco, Laccato opaco poro aperto.

Coffee table with solid ash structure. Top veneered ash in Cimento® or in polished marble. Available finishings: FN natural ash, CL american cherry, WG wengé, NC walnut, TB tobacco, Open pore matt lacquered.

coffee table
cod.5371



5371.50

5371.90



ø 50

ø 90



design Cesare Arosio e Beatrice Fanchini 2014

dominique

Tavolino con struttura in massello di frassino. Piano in legno placcato frassino, in Cimento®, in Laminam® o in marmo lucido. Finiture disponibili: FN frassino naturale, CL ciliegio americano, WG wengé, NC noce, TB tabacco, Laccato opaco poro aperto.

Coffee table with solid ash structure. Top veneered ash in Cimento® or in Laminam® or in polished marble. Available finishings: FN natural ash, CL american cherry, WG wengé, NC walnut, TB tobacco, Open pore matt lacquered.

coffee table
cod.5370

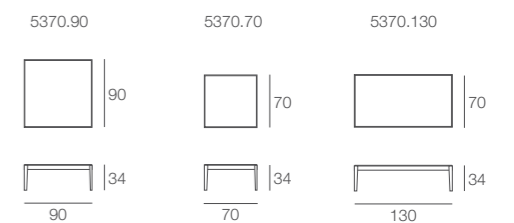

ACCESSORIES

accessori

dominique
binario
bunch
cloud
kali
charme
oblò



design Cesare Arosio e Beatrice Fanchini 2015

dominique

Consolle con struttura in massello di frassino. Piano in legno placcato frassino, in Cimento®, in Laminam® o in marmo lucido. Finiture disponibili: FN frassino naturale, CL ciliegio americano, WG wengé, NC noce, TB tabacco, Laccato opaco poro aperto.

Console with structure veneered ash. Top veneered ash, in Cimento®, Laminam® or in polished marble. Available finishings: FN natural ash, CL american cherry, WG wengé, NC walnut, TB tobacco, Open pore matt lacquered.

console
cod.5350

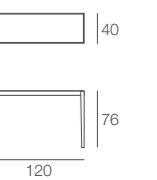



arch. Fabio Rebosio 2011

binario

Mensola placcata noce canaletto, frassino o in fibra di legno. Ripiano in vetro temperato. Finiture disponibili: WG wengé, NC noce, TB tabacco, NK noce canaletto, Laccato opaco poro aperto, Laccato opaco poro chiuso, Laccato brillante.

Shelf veneered canaletto walnut, ash or in fiberboard. Shelf in tempered glass. Available finishings: WG wengé, NC walnut, TB tobacco, NK canaletto walnut, Open pore matt lacquered, Closed pore matt lacquered, Glossy lacquered.

shelf
cod.5597





design Giuliano e Gabriele Cappelletti 2014

bunch

Mensola con vano a giorno placcata frassino. Finiture disponibili: FN frassino naturale, CL ciliegio americano, WG wengé, NC noce, TB tabacco, Laccato opaco poro aperto.

Shelf with open unit veneered ash. Available finishings: FN natural ash, CL american cherry, WG wengé, NC walnut, TB tobacco, Open pore matt lacquered.

shelf
cod.5594





Studio Tecnico Pacini&Cappellini 2015

clod

Pouf con struttura in poliuretano espanso indeformabile a densità differenziata avvolto da fibra acrilica. Rivestimento capitonné in pelle, ecopelle o tessuto della collezione.

Pouf con struttura in poliuretano espanso indeformabile a densità differenziata avvolto da fibra acrilica. Rivestimento in pelle, ecopelle o tessuto.

Pouf with nondeformable polyurethane foam of different densities, covered with acrylic fiber. Covered in capitonné leather, eco-leather or fabric of the collection.

Pouf with nondeformable polyurethane foam of different densities, covered with acrylic fiber. Covered in capitonné leather, eco-leather or fabric of the collection.

pouf capitonné
 cof.5346
 pouf
 cod.5347

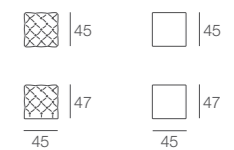



arch. Fabio Rebosio 2015

kali

Elemento appendiabiti in
massello di frassino.
Finiture disponibili: FN
frassino naturale, CL
ciliegio americano, WG
wengé, NC noce, TB
tabacco, Laccato opaco
poro aperto.

Clothes hanger element
in solid ash. Available
finishings: FN natural
ash, CL american cherry,
WG wengé, NC walnut,
TB tobacco, Open pore
matt lacquered.

clothes hanger element
cod.5511





design Cesare Arosio e Beatrice Fanchini 2014

charme

Coppia di specchi quadrati inclinati. Possibilità di fissaggio in diverse posizioni

Couple of mirrors, square shaped and inclined. Assembling possible in different positions.

mirror
cod.5523





design Studio Controdesign 2009

oblò

Specchio da parete con cornice placcata frassino o in fibra di legno. Possibilità di creare varie composizioni. Finiture disponibili: WG wengé, NC noce, TB tabacco, Laccato opaco poro aperto, Laccato opaco poro chiuso.

Wall mirror with veneered or lacquered frame. Assembling possible in different configurations. Available finishings: WG wengé, NC walnut, TB tobacco, Open pore matt lacquered, Closed pore matt lacquered.



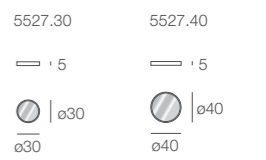







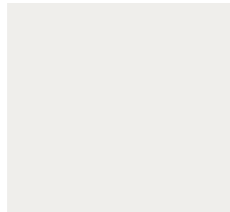

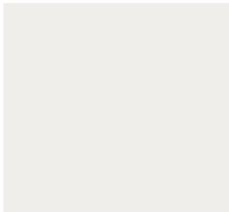











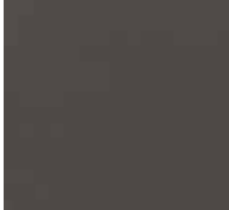

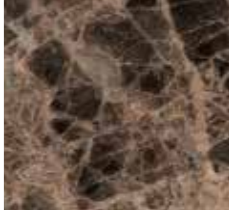



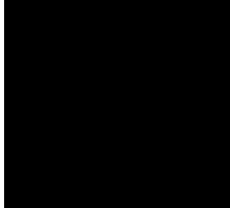

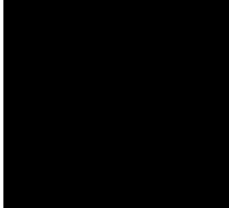
mirror
cod.5527



FINISHINGS

finiture

finishings

	laccato brillante glossy lacquered	laccato opaco poro aperto open pore matt lacquered	laccato opaco poro chiuso close pore matt lacquered	laccato opaco poro chiuso microgoffrato microembossed closed pore matt lacquered		legni woods		marmi marble			
L6 bianco brillante glossy white		L21 bianco opaco poro aperto open pore matt white		L1 bianco opaco poro chiuso closed pore matt white		L40 beige microgoffrato microembossed beige		NK noce canaletto canaletto walnut		BC marmo bianco carrara lucido polished white carrara marble	
L9 madreperla brillante glossy pearl		L29 madreperla opaco poro aperto open pore matt pearl		L19 madreperla opaco poro chiuso closed pore matt pearl		L41 ecrù microgoffrato microembossed ecrù		NC frassino tinto noce ash stained walnut		NM marmo nero marquinia lucido polished black marquinia marble	
L10 cappuccino brillante glossy cappuccino colour		L23 cappuccino opaco poro aperto open pore matt cappuccino colour		L3 cappuccino opaco poro chiuso closed pore matt cappuccino colour		L42 fango microgoffrato microembossed mud		TB frassino tinto tabacco ash stained tobacco		EM marmo emperador dark lucido polished dark emperador marble	
L11 grigio fumo brillante glossy smoke grey		L25 grigio fumo opaco poro aperto open pore matt smoke grey		L5 grigio fumo opaco poro chiuso closed pore matt smoke grey			decapati decapé	WG frassino o noce canaletto tinto wengè ash or canaletto walnut stained wengè			cimento®
L8 nero brillante glossy black		L22 nero opaco poro aperto open pore matt black		L2 nero opaco poro chiuso closed pore matt black		DN frassino decapato naturale natural decapè ash		CL frassino tinto ciliegio americano ash stained american cherry		C02 sabbia sand	
L7 rosso brillante glossy red		L24 rosso opaco poro aperto open pore matt red		L4 rosso opaco poro chiuso closed pore matt red		DT frassino decapato tortora dove decapè ash		FN frassino naturale natural ash		C03 tortora dove	
						DG frassino decapato grigio grey decapè ash					

photos : Riccardo Bianchi
styling & set project : Morena Colombo
graphic design : Lorenzo De Grandis
photoengraving: Tonality
printing: Grafiche Boffi
© Pacini&Cappellini, 2015

thanks to:
Flexform
Giorgio Braghieri
De Vecchi Milano 1935
Isella Moda Meda
Dall'enologo Giussano
Frigerio Salotti
Bodema
Berto Salotti

Pacini&Cappellini si riserva il diritto di apportare, senza preavviso, ogni modifica mirata al miglioramento funzionale e qualitativo dei propri prodotti. Testi e disegni presenti in questo stampato hanno scopo divulgativo: per ogni aspetto tecnico e dimensionale fare riferimento al listino aziendale e relativi aggiornamenti.

Pacini&Cappellini reserves the rights at all time to apply modifications for the functional or qualitative improvement of its products. Text and drawings present in this brochure have a divulgative purpose: for every technical and dimensional aspect please refer to the company's price list and their relevant updatings.

Pacini&Cappellini
via Kennedy, 18
22060 Cabiato
Como, Italy

tel 0039 031 767695
fax 0039 031 767588
info@paciniecappellini.it

www.paciniecappellini.it